

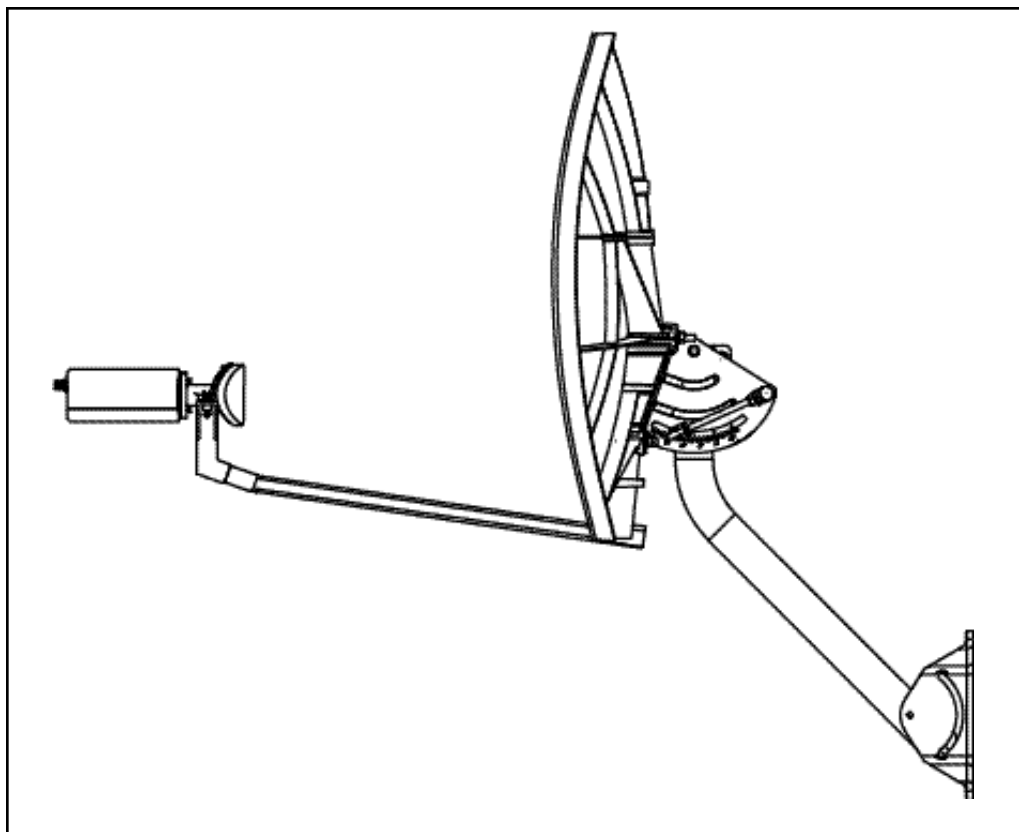

# Instruction and Assembly Manual

## 75 Elliptical Antenna System



7291 NW 74th Street • Miami, FL 33166  
GlobeCast Technical Service: (888) 988-5288

Manufactured By:



©2002 Channel Master LLC  
Printed in U.S.A.  
8000915-02  
11/02

**DANGER!!!**

**WATCH FOR WIRES! Installation of this product near power lines is dangerous. For your own safety, follow these important safety rules.**

1. Perform as many functions as possible on the ground.
2. Watch out for overhead power lines. Check the distance to the power lines before starting installation. We recommend you stay a minimum of 6 meters (20 feet) from all power lines.
3. Do not use metal ladders.
4. Do not install antenna or mast assembly on a windy day.
5. If you start to drop antenna or mast assembly, get away from it and let it fall.
6. If any part of the antenna or mast assembly comes in contact with a power line, call your local power company. **DO NOT TRY TO REMOVE IT YOURSELF!** They will remove it safely.
7. Make sure that the mast assembly is properly grounded.

**WARNING!!!**

Antenna installations requiring the installer to work elevated above the ground level should be performed only by trained professional installers. Failure to comply may result in personal injury or death.

**WARNING!!!**

Assembling dish antennas on windy days can be dangerous. Because of the antenna surface, even slight winds create strong forces. For example, a 1.0m antenna facing a wind of 32 km/h (20 mph) can undergo forces of 269 N (60 lbs). Be prepared to safely handle these forces at unexpected moments. Do not attempt to assemble, move or mount a dish on windy days or serious, even fatal accidents may occur. The manufacturer is not responsible or liable for damage or injury resulting from antenna installations.

**WARNING!!!**

Antennas improperly installed or installed to an inadequate structure are very susceptible to wind damage. This damage can be very serious or even life threatening. The owner and installer assumes full responsibility that the installation is structurally sound to support all loads (weight, wind & ice) and properly sealed against leaks. The manufacturer will not accept liability for any damage caused by a satellite system due to the many unknown variable applications.

# INTRODUCTION

This Installation Manual provides all the information you require to install your system. The instructions are fairly simple, providing step-by-step instruction for system installation. However, it will require skills in construction, wiring and assembly to correctly complete the installation.

**WARNING: All satellite dish systems must be properly grounded. National and local electrical codes may require you to ground the dish directly and to insert a grounding block in the coaxial cables running from the dish to the receiver inside the building. Before beginning installation, carefully read the section on grounding the dish.**

## ASSEMBLY TOOLS REQUIRED

This installation requires you to:

- Use hand tools such as a hand drill
- Determine whether water pipes, electrical wiring or gas lines are close to the installation area
- Route coaxial cable through walls and under floors
- Use a compass, protractor and carpenter's level
- Use a ladder to climb structures
- Know your local and national grounding codes

If you feel you do not have the experience to perform these tasks, contact your satellite retailer to arrange for installation.

You will need the following tools:

- #1 Phillips Screwdriver
- 1/2 or 13 Hex Wrench, open or combination end
- Electric Drill and Bits
- Carpenter's Level
- Compass
- Protractor

## BOLT TORQUE

### GRADE 8.8 (8G) - GOLD COLOR



**APPLY 24 N-m (18 ft.-lbs.) OF TORQUE TO M8 BOLT**

M6	M8	M10	M12	M16	M20
9.5 N-m	24 N-m	43 N-m	79 N-m	195 N-m	353 N-m
7 ft-lbs.	18 ft-lbs.	32 ft-lbs.	58 ft-lbs.	144 ft-lbs.	260 ft-lbs.

NOTE: TORQUE FOR M8 ROUND HEAD, SQUARE NECK BOLT IS 16.3 N-m (12 ft-lbs.)

Your 75E Elliptical Dish Kit comes with the following components:

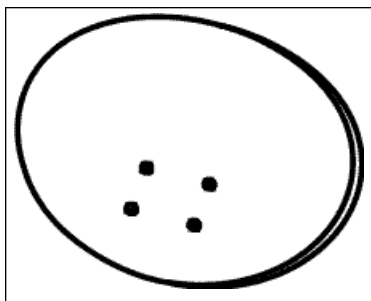

75E Elliptical Dish

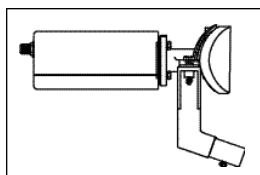

75E Satellite LNB/Feedhorn Clamp Assembly

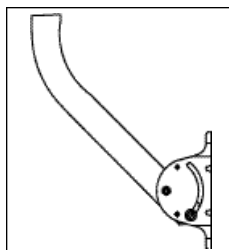

2" diameter Universal Mount Assembly

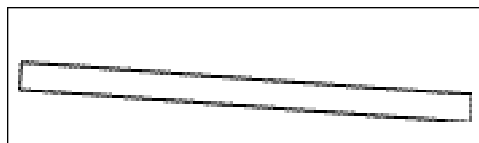

Satellite Feed Support Arm

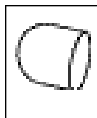

1 LNB Weather Cap

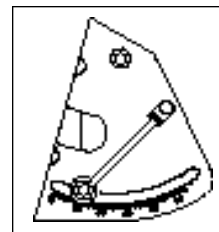

75E Az/EI Clamp Mount Assembly

Key points to remember when installing your 75E Elliptical Antenna System:

- Do not drill any holes until you've confirmed the best location for the dish.
- Make sure the installation of the dish conforms to local electrical and building codes, zoning requirements and other applicable laws and regulations. If you are unsure, contact your local electrician or building inspector for assistance.
- For possible periodic removal of snow, choose a site that is easily accessible.
- Ensure there are no visible obstructions between the dish and your line of sight to the satellites. Keep in mind that trees will grow up and outward and may eventually block the signal.
- The maximum allowable length for the RG-6 coaxial cable connecting the receiver to your dish is 125 feet.
- Use only RG-6 grade coaxial cable. Using lower grade RG-59 coaxial cable may result in excessive signal loss and poor reception. Cable grade type is indicated on the outer jacket.
- Do not install the dish:
  - Under power lines
  - Where it may be easily tampered with
  - Where it is exposed to high winds
  - During windy or stormy conditions

## **MOUNTING LOCATIONS**

Your dish must be mounted on a solid base. To ensure your dish doesn't move in windy conditions, choose a location where it can be securely fastened. The mounting surface should be rigid and solid.

**IMPORTANT: The Elliptical Dish has a minimum turn radius of +/- 35 degrees. If you are mounting the dish on the side of your house, check the assembled dish and mounting pole to see if you can rotate the dish in the desired azimuth setting. If you can't rotate the dish, choose an alternate location.**

**Key things to remember when choosing a mounting location:**

- The mounting surface should be flat, even and in good condition.
- If you install the dish on the roof or side of your house, be sure to attach the bolts into a building stud, rafter or other solid surface.
- When mounting on the roof of your house, use silicon sealant around the holes where the base of the universal mount meets the mounting surface. This will prevent the roof from leaking.
- **We do not recommend:**
  - Mounting the dish on a railing
  - Installing the dish on aluminum or vinyl siding (these are unlikely to be structurally sound)
- Keep grounding requirements in mind.

## DISH ASSEMBLY

**Step 1:** To avoid losing any hardware components, select a clear area on the ground for dish assembly.

**Step 2:** On the Universal Mount, insert the (2) 20 mm Carriage Head Bolts (Mast Adjusting Bolts), through the mast and the curved slot of the mount (Figure A).

**Step 3:** Attach the dish to the Clamp Mount Assembly using the (2) 91mm and (2) 56mm long Carriage Head Bolts (Antenna Mounting Bolts-Painted Head), (4) Skew Lock Clips, (4) Lock washers and (4) Nuts (see Figure B). Before tightening the (4) bolts, refer to Skew Setting Chart on Page 8 & 9 for the correct skew setting for your geographic location.

**Note:** For single feed systems, tighten and torque the 4 bolts now as further adjustment will not be required.

**Step 4:** Pre-route the RG6 Coaxial Cable through the Feed Support Arm then attach the Feed Support arm to the dish using the 60mm Screw Bolt, 5/16 Flat Washer, Spacer and Nut, making sure the Feed Support Arm and Spacer Sleeve are positioned as shown in Figure C.

**Important:** Installation of the Spacer is mandatory to maintain rigidity. Ensure you tighten the Feed Support Arm securely.

**FIG. A**

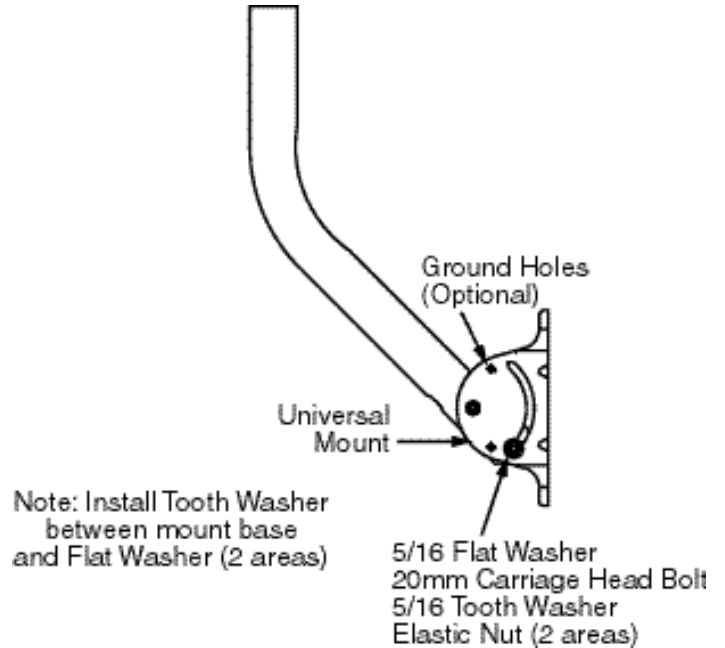

**FIG. B**

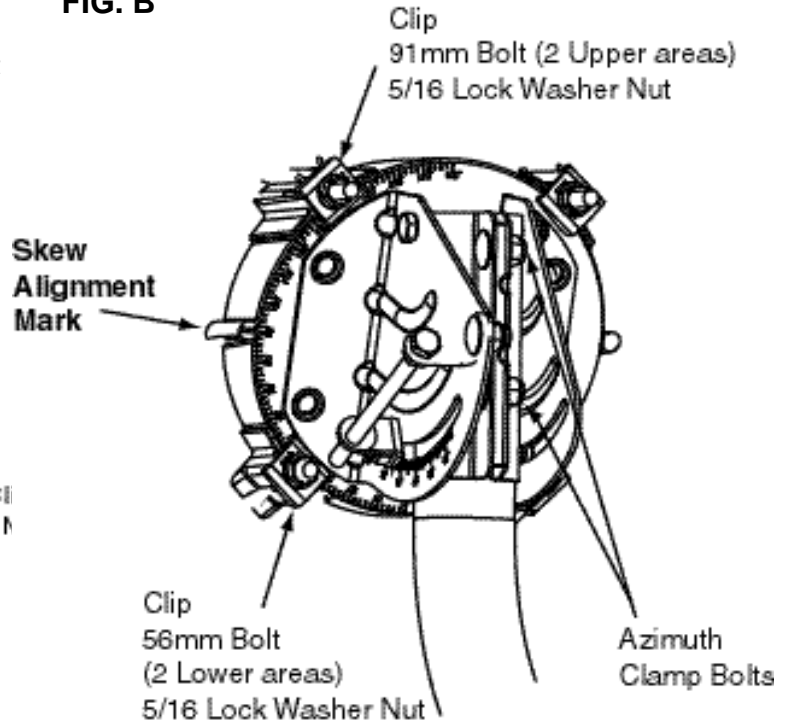

**FIG. C**

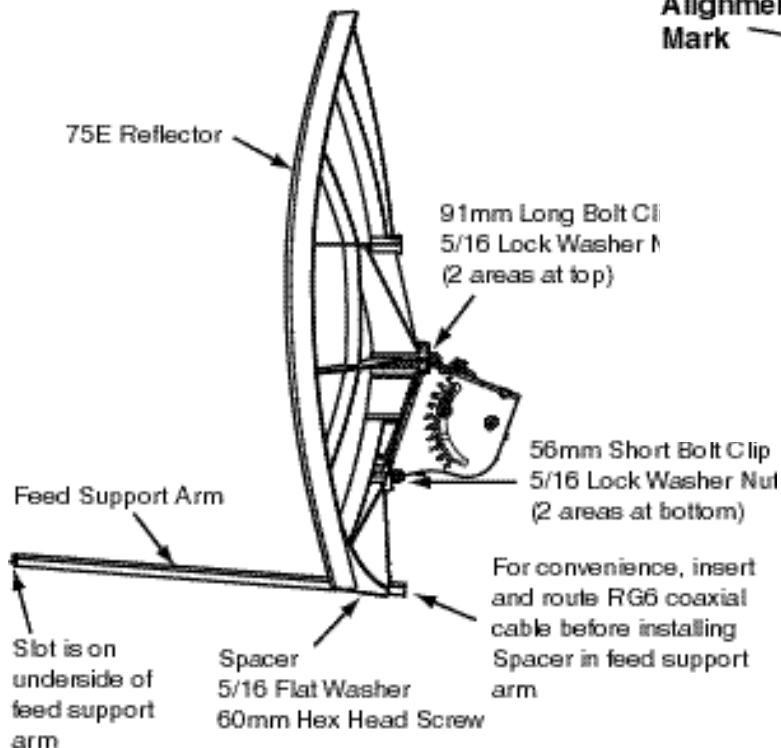

# LOCATING THE SATELLITE

**Step 1:** Determine the direction in which to point the dish. Refer to the Satellite Alignment Chart on Page 8 & 9. Record value below.

**“Initial Setting” starting reference from the Locator Chart**

Azimuth	Elevation	Skew
_____	_____	Set during Az/EI Mount Attachment to the Dish

**Step 2:** Use a compass to determine roughly where to point your dish.

**Step 3:** Choose a dish installation location with a clear line of sight to the satellite based on the settings you recorded earlier. There should be no trees, buildings or other obstructions between the dish and the satellite. Do you have a clear line of sight to the satellite?

- If YES, go to Step 4 and continue with the installation.
- If NO, find another location.

**NOTE:** To ensure an accurate compass reading, stay away from large metal objects. To double-check accuracy, take multiple readings several feet apart.

**Step 4:** At the dish install site, hold a compass level and still in the palm of your hand. When the needle stops rotating (dark half of the needle always points north), slowly rotate the body of the compass so that the "N" marking is aligned with the dark half of the needle. Locate the tick mark on the compass edge corresponding to the SAT azimuth number you wrote down earlier. This is the direction in which to point your dish to receive signals.

**TIP:** Use a stick or other distant object to mark the “initial setting” compass azimuth direction for SAT. Figure D).

**Step 5:** Estimate the satellite elevation (angle) settings you recorded earlier, using a protractor. Check any obstructions at that elevation. If there are obstructions, then select an alternate location for the dish.

**IMPORTANT:** When evaluating the install location, make sure there are no trees, branches or objects visually obstructing the dish and the general direction of the satellite. Also, keep in mind that trees grow up and outward and may eventually block the signal.

## Azimuth

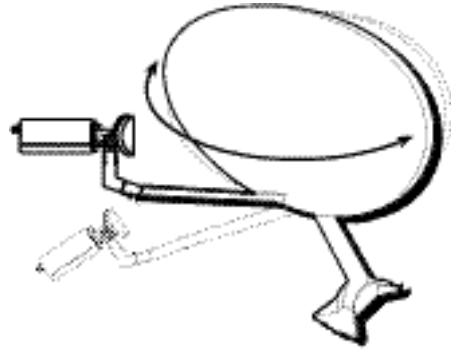

## Elevation

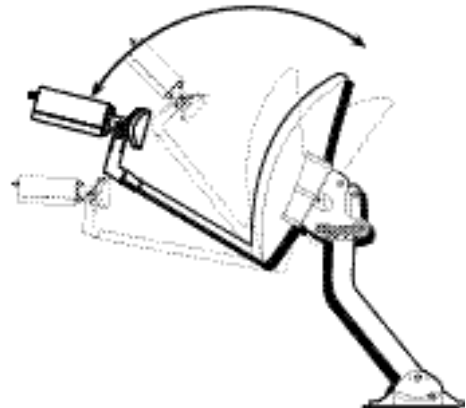

**FIG. D**

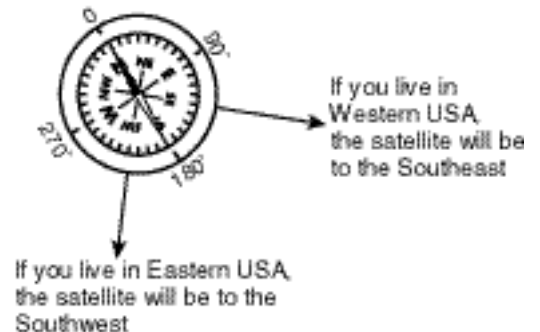

## ATTACHING THE DISH

**Step 1:** Ensure mast is plumb before drilling any holes. Hold the Universal Mount in place on the mounting area. Use a carpenter's level to plumb the antenna mast's straight section. If the bubble levels (horizontal and vertical) are not centered, rotate the mast (in the curved slot) until it is plumb. Then lock it in place by securely tightening the Mast Adjusting Bolts (see Figure E).

**IMPORTANT:** Initially finding the correct satellite signal and turning to the satellite will be more difficult if the mast is not plumb. Ensure the mast is plumb.

**Step 2:** Drill holes in the structure on which you are mounting the dish to match the holes in the base of the Universal Mount.

**Step 3:** Secure the Universal Mount with appropriate surface screws (not included). Check the mount for movement. An improperly secured mount will reduce signal reception and reliability at a later date.

**Step 4:** Slide the Dish/Clamp Mount Assembly onto the mast by loosening the (2) Azimuth Clamp Bolts (see Figure B) and the Elevation Pivot Bolt just enough to slide the assembly until it makes contact with the Elevation Pivot Bolt (see Figure F). Tighten the Elevation Pivot Bolt just enough to hold it in place on the mast.

**Step 5: POLARIZATION SETTING:** Polarization of the feed is not needed. It should be set to zero from the factory.

**Step 6: ELEVATION SETTING:** Loosen the (2) Elevation Locking Bolts sufficiently about 1 to 2-turns from tight on either side of the Clamp Mount Assembly. Then using the Fine Tuning Elevation Adjustment Bolt carefully adjust the dish elevation to the setting you recorded earlier. Tighten the (2) Elevation Locking Bolts and re-check the dish elevation setting to ensure the setting has not changed. (See Figure F).

**Step 7: INITIAL AZIMUTH SETTING.** Using your compass, point the Feed Support Arm in the direction corresponding to the azimuth setting (see Figure G). Draw a vertical mark overlapping the Clamp Mount Assembly and the mast. This mark will provide you with the approximate starting reference point when you're ready to find and tune to the satellite.

FIG. E

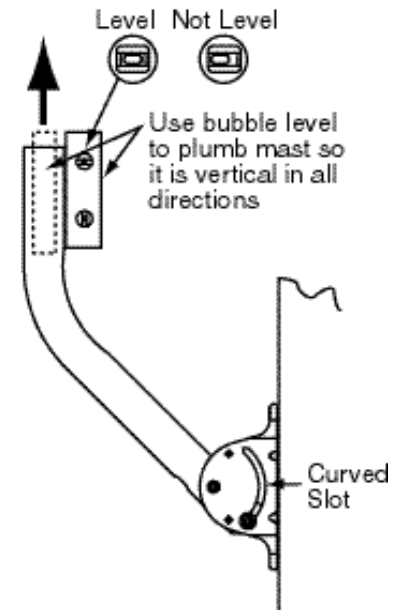

FIG. F

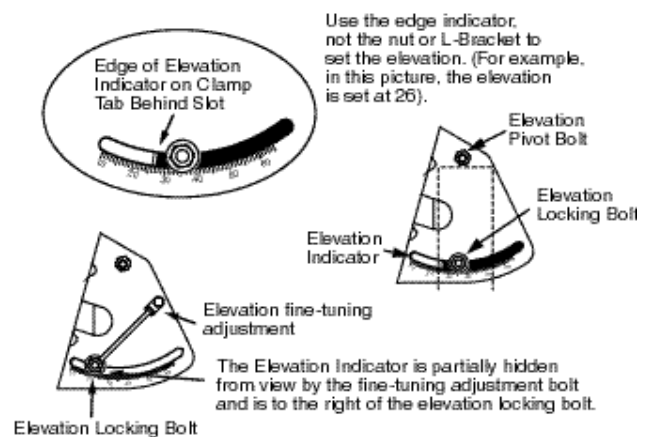
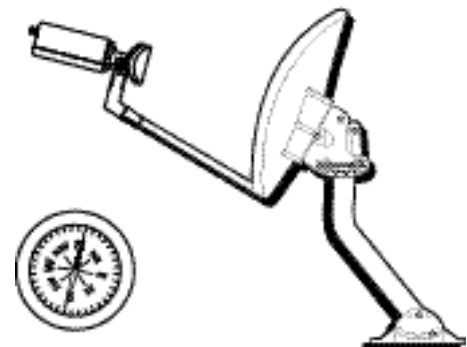

FIG. G



- Step 8:** Connect one end of the RG6 coaxial cable to the LNB feedhorn assembly. To install Weather Cap, gently bend the cable to carefully fit the Weather Cap onto the LNB. Insert cap only about 1/2 inch. Avoid sharp bends to the cable.
- Step 9:** Before beginning the Tuning to the Satellite process, now is a good opportunity to sufficiently loosen the (2) azimuth clamp bolts, the elevation pivot bolt and the (2) Elevation Locking Bolts and allow the dish to naturally settle on the dish pole. While moving the dish back and forth on the pole, slowly and evenly torque all Azimuth Clamp Bolts, Elevation Pivot Bolt and Elevation Locking Bolts. Eventually tighten all bolts to allow the Azimuth and Elevation Clamp assembly to be firmly secured on the pole. The dish should not be able to be rotated on the pole with both hands. This step will be helpful in minimizing dish movement after tuning.
- Step 10: FINE TUNING:** Follow instructions in the Satellite Receiver Manual or use signal strength measuring device for final adjustments to obtain maximum antenna performance. Rotate antenna and Az-El cap, pointing to the correct compass reading that was recorded earlier. **Slowly** sweep the antenna in azimuth until a signal is found. If desired signal is not found, increase or decrease the elevation setting (in 1/2° increments) and repeat the azimuth sweep. Alternate between elevation and azimuth fine tuning to reach maximum signal strength until no further improvement is detected. Tighten and torque all hardware, referring to the Torque Chart on Page 1.

## GROUNDING

### General Grounding Requirements for Outdoor Unit

*Refer to National Electric and Local Codes for complete requirements.*

The National Electric Code is published by the National Fire Protection Association  
1 Batterymarch Park  
Quincy, Massachusetts, 02269-9959  
and may be available at your local public library

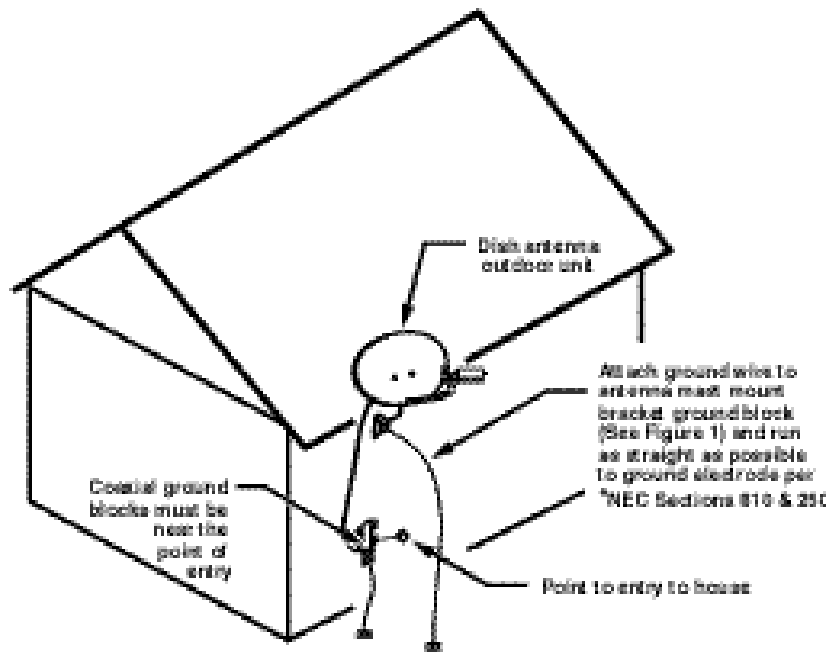

LONGITUDE

LATITUDE

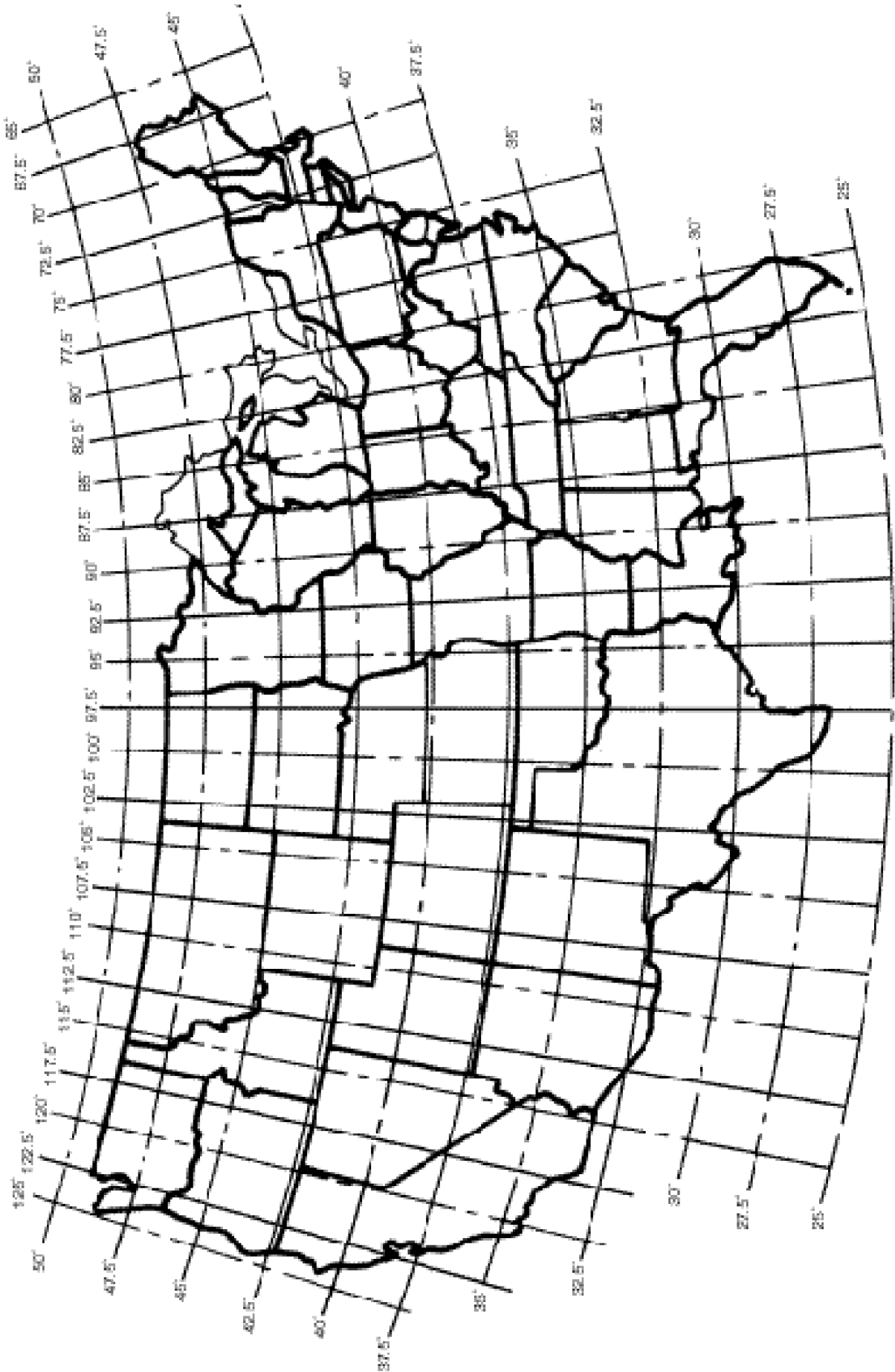

## TELSTAR 5 SATELLITE 97° W IN 25° INCREMENTS

<u>LAT.</u>	<u>LONG.</u>	<u>AZ</u>	<u>EL</u>	<u>SKEW</u>	<u>LAT.</u>	<u>LONG.</u>	<u>AZ</u>	<u>EL</u>	<u>SKEW</u>
25	80.0	221	55	122	35	75.0	226	43	118
25	82.5	215	57	118	35	77.5	221	44	115
25	85.0	209	58	114	35	80.0	215	45	113
25	87.5	202	59	109	35	82.5	210	46	110
25	90.0	195	60	105	35	85.0	204	47	107
25	92.5	188	60	100	35	87.5	198	48	103
25	95.0	180	61	94	35	90.0	192	49	100
25	97.5	173	61	89	35	92.5	186	49	96
25	100.0	166	61	84	35	95.0	180	49	93
					35	97.5	174	49	89
27.5	75.0	230	50	126	35	100.0	168	49	86
27.5	77.5	225	51	123	35	102.5	162	49	82
27.5	80.0	219	53	119	35	105.0	157	48	79
27.5	82.5	213	54	116	35	107.5	151	48	75
27.5	85.0	207	55	112	35	110.0	146	47	72
27.5	87.5	200	56	108	35	112.5	142	46	69
27.5	90.0	194	57	103	35	115.0	137	45	66
27.5	92.5	187	58	99	35	117.5	133	44	63
27.5	95.0	180	58	94	35	120.0	129	43	61
27.5	97.5	173	58	89					
27.5	100.0	167	58	84	37.5	75.0	225	41	116
27.5	102.5	160	57	80	37.5	77.5	220	42	114
27.5	105.0	154	57	75	37.5	80.0	215	43	111
					37.5	82.5	209	44	108
30	75.0	229	48	123	37.5	85.0	203	45	105
30	77.5	223	49	120	37.5	87.5	197	45	102
30	80.0	218	50	117	37.5	90.0	191	46	99
30	82.5	212	52	113	37.5	92.5	185	46	96
30	85.0	206	53	110	37.5	95.0	179	46	93
30	87.5	199	54	106	37.5	97.5	174	47	89
30	90.0	193	54	102	37.5	100.0	168	46	86
30	92.5	186	55	98	37.5	102.5	162	46	83
30	95.0	180	55	93	37.5	105.0	157	46	80
30	97.5	173	55	89	37.5	107.5	152	45	77
30	100.0	167	55	85	37.5	110.0	147	44	74
30	102.5	161	55	81	37.5	112.5	143	44	71
30	105.0	155	54	76	37.5	115.0	138	43	68
30	107.5	150	53	72	37.5	117.5	134	41	65
30	110.0	144	52	69	37.5	120.0	130	40	63
30	112.5	139	51	65	37.5	122.5	127	39	61
30	115.0	135	50	62	37.5	125.0	123	38	59
32.5	75.0	227	45	120	40	70.0	234	36	118
32.5	77.5	222	47	118	40	72.5	229	37	116
32.5	80.0	216	48	115	40	75.0	225	38	114
32.5	82.5	211	49	111	40	77.5	220	40	112
32.5	85.0	205	50	108	40	80.0	214	40	109
32.5	87.5	199	51	105	40	82.5	209	41	107
32.5	90.0	192	51	101	40	85.0	203	42	104
32.5	92.5	186	52	97	40	87.5	197	43	101
32.5	95.0	180	52	93	40	90.0	191	43	98
32.5	97.5	173	52	89	40	92.5	185	43	95
32.5	100.0	167	52	85	40	95.0	179	44	92
32.5	102.5	162	52	81	40	97.5	174	44	89
32.5	105.0	156	51	78	40	100.0	168	44	86
32.5	107.5	151	51	74	40	102.5	163	43	83
32.5	110.0	146	50	71	40	105.0	157	43	81
32.5	112.5	141	49	67	40	107.5	152	42	78
32.5	115.0	136	47	64	40	110.0	148	42	75
32.5	117.5	132	46	61	40	112.5	143	41	72
32.5	120.0	128	45	58	40	115.0	139	40	70
					40	117.5	135	39	67
					40	120.0	131	38	65
					40	122.5	127	37	63
					40	125.0	124	35	61

<u>LAT.</u>	<u>LONG.</u>	<u>AZ</u>	<u>EL</u>	<u>SKEW</u>	<u>LAT.</u>	<u>LONG.</u>	<u>AZ</u>	<u>EL</u>	<u>SKEW</u>
42.5	70.0	233	34	116	50	70.0	234	27	111
42.5	72.5	229	35	114	50	72.5	229	28	109
42.5	75.0	224	36	112	50	75.0	225	29	107
42.5	77.5	219	37	110	50	77.5	220	30	106
42.5	80.0	214	38	108	50	80.0	215	30	104
42.5	82.5	208	39	105	50	82.5	209	31	102
42.5	85.0	203	39	103	50	85.0	204	32	100
42.5	87.5	197	40	100	50	87.5	198	32	98
42.5	90.0	191	40	98	50	90.0	192	32	96
42.5	92.5	185	41	95	50	92.5	186	33	94
42.5	95.0	179	41	92	50	95.0	180	33	92
42.5	97.5	174	41	89	50	97.5	174	33	90
42.5	100.0	168	41	87	50	100.0	169	33	87
42.5	102.5	163	41	84	50	102.5	163	32	85
42.5	105.0	158	40	81	50	105.0	158	32	83
42.5	107.5	153	40	79	50	107.5	153	32	81
42.5	110.0	148	39	76	50	110.0	147	31	79
42.5	112.5	144	38	74	50	112.5	144	31	77
42.5	115.0	139	38	71	50	115.0	140	30	75
42.5	117.5	135	37	69	50	117.5	136	29	74
42.5	120.0	132	36	67	50	120.0	132	29	72
42.5	122.5	128	35	65	50	122.5	129	28	70
42.5	125.0	125	33	63	50	125.0	125	27	68
45	70.0	233	32	114					
45	72.5	229	33	113					
45	75.0	224	34	111					
45	77.5	219	35	108					
45	80.0	214	35	106					
45	82.5	208	36	104					
45	85.0	203	37	102					
45	87.5	197	37	99					
45	90.0	191	38	97					
45	92.5	185	38	94					
45	95.0	180	38	92					
45	97.5	174	38	90					
45	100.0	168	38	87					
45	102.5	163	38	85					
45	105.0	158	38	82					
45	107.5	153	37	80					
45	110.0	148	37	77					
45	112.5	144	36	75					
45	115.0	140	35	73					
45	117.5	136	34	71					
45	120.0	132	33	69					
45	122.5	128	32	67					
45	125.0	125	31	65					
47.5	70.0	233	29	113					
47.5	72.5	229	30	111					
47.5	75.0	224	31	109					
47.5	77.5	219	32	107					
47.5	80.0	214	33	105					
47.5	82.5	209	34	103					
47.5	85.0	203	34	101					
47.5	87.5	197	35	99					
47.5	90.0	191	35	96					
47.5	92.5	186	35	94					
47.5	95.0	180	35	92					
47.5	97.5	174	35	90					
47.5	100.0	168	35	87	<b>AZ</b>	=	<b>Azimuth Heading, Direct Compass Reading (Magnetic Deviation has been included in the chart.)</b>		
47.5	102.5	163	35	85					
47.5	105.0	158	35	83	<b>EL</b>	=	<b>Elevation in Degrees, Direct Reading</b>		
47.5	107.5	153	34	81	<b>SKEW</b>	=	<b>Antenna "Tilt" setting using the Az/El mount skew scale.</b>		
47.5	110.0	148	34	78					
47.5	112.5	144	33	76					
47.5	115.0	140	33	74					
47.5	117.5	136	32	72					
47.5	120.0	132	31	70					
47.5	122.5	129	30	68					
47.5	125.0	125	29	67					

## **MANUFACTURER'S ANTENNA/MOUNT/LNB LIMITED TWELVE (12) MONTH WARRANTY**

This equipment is warranted to be free from defects in material and workmanship under normal use and service. The manufacturer shall repair or replace defective equipment, at no charge, or at its option, refund the purchase price, if the equipment is returned not more than twelve (12) months after shipment. Removal or reinstallation of equipment and its transportation shall NOT be at the cost of the manufacturer except the manufacturer shall return repaired or replaced equipment freight prepaid.

This Warranty shall not apply to equipment which has been repaired or altered in any way so as to affect its stability or durability, or which has been subject to misuse, negligence or accident. This Warranty does not cover equipment which has been impaired by severe weather conditions such as excessive wind, ice, storms, lightning, or other natural occurrences over which the manufacturer has no control, and this Warranty shall not apply to equipment which has been operated or installed other than in accordance with the instructions furnished by the manufacturer.

Claimants under this Warranty shall present their claims along with the defective equipment to the manufacturer immediately upon failure. Non-compliance with any part of this claim procedure may invalidate this warranty in whole or in part.

THIS WARRANTY IS EXPRESSLY IN LIEU OF ALL OTHER AGREEMENTS AND WARRANTIES, ANY IMPLIED WARRANTY OF MERCHANTABILITY OR FITNESS FOR A PARTICULAR PURPOSE IS LIMITED IN DURATION TO THE DURATION OF THIS WARRANTY. THE MANUFACTURER DOES NOT AUTHORIZE ANY PERSON TO ASSUME FOR IT THE OBLIGATIONS CONTAINED IN THIS WARRANTY AND THE MANUFACTURER NEITHER ASSUMES NOR AUTHORIZES ANY REPRESENTATIVE OR OTHER PERSON TO ASSUME FOR IT ANY OTHER LIABILITY IN CONNECTION WITH THE EQUIPMENT DELIVERED OR PROVIDED.

IN NO EVENT SHALL THE MANUFACTURER BE LIABLE FOR ANY LOSS OF PROFITS, LOSS OF USE, INTERRUPTION OF BUSINESS, OR INDIRECT, SPECIAL OR CONSEQUENTIAL DAMAGES OF ANY KIND.

In no event shall the manufacturer be liable for damages in an amount greater than the purchase price of the equipment.

Some states do not allow limitations on how long an implied warranty lasts, or allow the exclusion or limitation of incidental or consequential damages, so the above limitations or exclusions may not apply to you.