

TECHNICAL INFORMATION BULLETIN

Products Affected: Power Inserter, SW21 Switch, SW44 Switch, and SW64 Switch

Subject: Important Instructions for Installing Switches with a Power Inserter

Problem

In installations where an SW21 switch is cascaded with an SW44 or SW64 switch to add another antenna, it is possible to damage the SW21 switch if the SW21 switch is placed between the power inserter and the SW44 or SW64 switch.

Solution

When installing the SW21 switch in the same cable run as the power inserter, install the SW21 switch between the receiver and the power inserter (see the figures below).

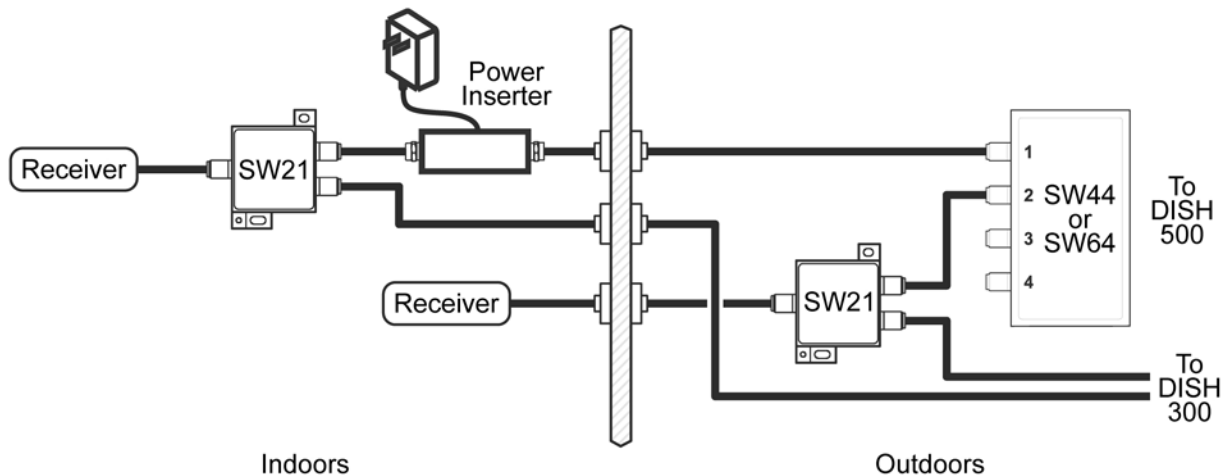

Figure 1 - Installation with Power Inserter and SW21 on the Same Cable

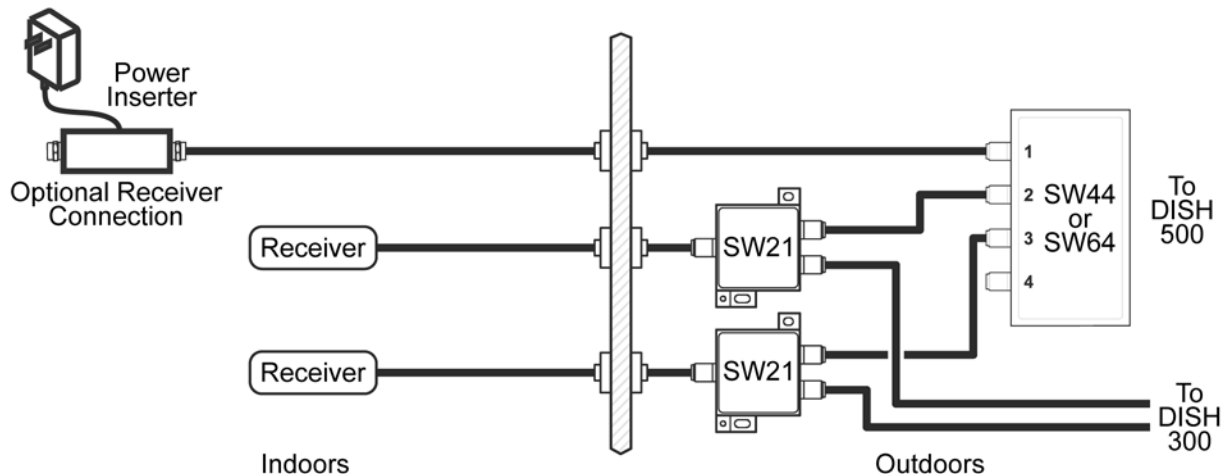

Figure 2 – Alternate Installation Using a Power Inserter on a Dedicated Cable